

A comparative Study of the Determination of Diclofenac sodium in pharmaceutical Formulations by flow injection chemiluminescence and High performance liquid Chromatography

Ali Ibraheem Khaleel, Suham T. amine and Abdul Barry.M. Mahood
Chemistry Department, College of Education, Tikrit University, Iraq

(NJC)

(Received on 11/3 /2006) (Accepted for publication on 19/8/2006)

Abstract

This study involves development of a new flow injection chemiluminescence(FI-CL),andhighperformanceliquid chromatography(HPLC) methods for the determination of Diclofenac sodium (D.S) in pharmaceutical tablets preparations.

Chemiluminescence method was based on inhibition of the (CL) of luminol-hydrogen peroxide system catalyzed by cobalt in alkaline medium producing a blue Luminescence. In the presence of (DS), cobalt (II) reacts immediately with this drug forming inactive complex preventing the catalytic effect of cobalt (II) Ion. In this case an inhibition of the (CL) occurs which is proportional to the amount of the drug added. The linearity of this method was in the range of (0.9858-8.904) $\mu\text{g ml}^{-1}$ with a correlation coefficient of 0.9969, a relative standard deviation (RSD) 0.463 %, with detection limit of (0.410) $\mu\text{g ml}^{-1}$.

In HPLC method the drug was analyzed by Reverse phase HPLC (Rp-HPLC) method using a suspect ODSC₁₈ (25 cm \times 4.6 mm id)with (5 μm particle size) and isocratic elution with a mobile phase containing 16% acetonitrile in 0.02M sodium acetate buffer pH(5.5) at flow rate of 1m min^{-1} , 20 μl sample loop, temperature 30C⁰ and the uv-detector was set at λ max 220 nm. The Linearity was in the range of (10-60) $\mu\text{g l}^{-1}$ with a correlation coefficient of 0.9945 and the RSD 0.64 %, with a detection limit 3.4 $\mu\text{g l}^{-1}$

The two methods have been applied successfully to the determination of (D.S) in tablets formulation with mean recovery (96.6- 98.48%).

الخلاصة

تضمنت هذه الدراسة تقدير المركب الدوائي diclofenac sodium بطريقتين تحليليتين، ففي الطريقة الأولى استخدمت طريقة الحقن الجرياني المقترن بالبريق الكيميائي بواسطة تثبيط البريق لمركب اللومينول مع بيروكسيد الهيدروجين بوجود ايون الكوبلت (Co^{+2}) المحفز. وكان مدى الخطية بين (1-9) مايكروغرام/مل

ومعامل الارتباط (r) ٠,٩٩٦٩ وحده كشف ٠,٤٢ مايكروغرام/مل أما قيمة الانحراف القياسي النسبي RSD فكان ٠,٢٣ %.

أما في الطريقة الثانية فتم تطوير طريقة كروماتوغرافية جديدة لتقدير العقار (D.S) باستخدام الكروماتوغرافيا السائلة ذات الأداء العالي- الطورالعكوس Rp-HPLC باستخدام العمود ODSC₁₈ (٢٥ سم × ٤,٦ ملم) محشو بدقائق ذات أقطار ٥ مايكرومتر بازاحه ايزوكراتية (Isocratic elution) ويطور متحرك مكون من مزيج يحتوي ١٦,٠% أسيتونايترايل ومحلول منظم بتركيز ٠,٢ مولاري لضبط الدالة الحامضية عند pH=٥,٥ وبسرعة جريان (١) مل / دقيقة وحجم مادة محقنة ٢٠ مايكروليتر وبدرجة حرارة ٣٠^٥م^٥ وقياس الامتصاص عند ٢٢٠ نانوميتر. وكانت الحدود الخطية للطريقة (١٠ - ٦٠) مايكروغرام/مل. أما قيمة الانحراف القياسي النسبي وحده الكشف فكانا ٠,٧٢ % ، 3.4 مايكروغرام/ مل على التوالي وطبقت الطريقتين على المستحضرات الصيدلانية الحاوية على مادة Diclofenac sodium وبلغ الاسترداد ٩٦,٦-٩٨,٤٨ %.

Introduction

Diclofenac sodium(D.S.), sodium 2-[2,6-di chlorophenyl amino] phenyl] acetate⁽¹⁾ is acute treatment of mild to moderate pain, ankylosing spondylitis, primary dysmenorrheal, acute and chronic treatment of rheumatoid arthritis⁽²⁻³⁾.

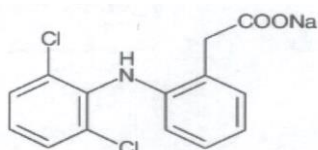

Many methods have been developed for the determination of (D.S) in various matrices such as pharmaceutical formulations, blood, urine and aqueous solutions. Hessian⁽⁴⁾ used plastic membrane electrode for selective determination of (D.S) in pharmaceutical preparations. The calibration graph was linear in the range of (0.05-1.0) mM and the detection limit was 0.023 mM. A capillary electrophoresis method for the determination of (D.S) in commercial simulated tablets formulation has been described by parodo⁽⁵⁾.The calibration curve was linear from (40-120) µg/ml with r = 0.9992.

Damian⁽⁶⁾ used a spectrofluorimetric method for the determination of D.S in tablets and

ointment. Fluorescence intensity was measured at 362 nm (excitation at 287 nm) calibration graph was linear from 0.2-5 mg ml⁻¹ with a detection limit of 0.2 µg /ml and the recovery ranged from 95% - 109% . A number of other techniques such as HPLC⁽⁷⁾reversed phase,NP-HPLC⁽⁸⁾ , TLC⁽⁹⁾,HPLC-MS⁽¹⁰⁾,Voltammetric and flow-injection spectrophotometric methods⁽¹¹⁾ have been reported for the assay of (D.S) in commercial dosage forms .

The present paper describes two developed methods for the determination of (D.S) in the pharmaceutical preparation samples. The first methods describes a flow injection chemiluminescence technique in the presence of luminol, H₂O₂ and cobalt ion Co⁺²,while the second describes Rp-HPLC method.

Experimental

(1)Chemiluminescence Apparatus:-

The Flow system (Fig.1) consisted of one peristaltic pump (PLC parapose model 132100) which delivers sample and H₂O₂- luminol streams. A PTFE tubing (0.5 mm i.d.) was used to connect all the components in the flow system. A rotary injection valve was used for sample injection and the signal was

recorded using Philips Recorder (PM 8251).

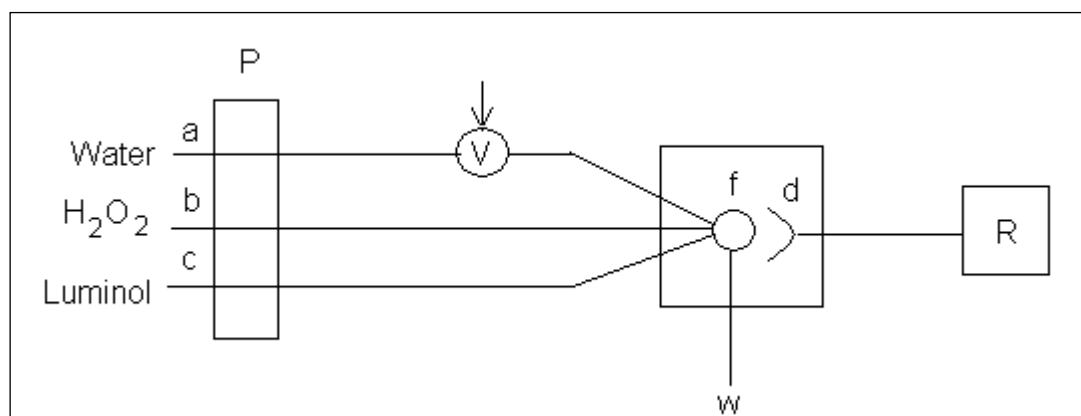

Fig(1) Schematic diagram of the flow injection system for the determination of (D.S).

(a) H₂O (b) H₂O₂ (c) luminol (p) peristaltic pump (v) injection valve (f) Flow cell (w) waste liquid (d) photomultiplier tube (R) Recorder.

(2) HPLC Apparatus

The analysis was performed on a CECIL 1100 HPLC (EC-200) UV-Visible detector of one solvent reservoir and high performance pump (pressure range (0-500 kg. cm⁻¹). The injection valve was Rheodyne 7125 USA and was fitted with 20 μl sample loop. Separation of drug was carried out on a (25 cm × 4.6 mm.id) stainless steel (5 μm) particle size) ODS-C18 reversed-phase provided from Supelco.

First method

Determination of Diclofenac sodium using a new Flow injection chemiluminescence

Reagents

Luminol (FLuka), Hydrogen peroxide, CoCl₂.6H₂O, H₂SO₄ (96%) (BDH), while Diclofenac sodium and other materials were donated from (S.D.I).

Preparation of Stock Solutions

The D.S (100) μg/ml was prepared by dissolving 0.0100 gm D.S in 100 ml of distilled water. The luminol stock solution (0.001) mol.l⁻¹ was prepared by dissolving 0.3543 gm in 2L of 0.1M Na₂CO₃ (21.1 gm/l distilled water). Stock solution of

100 μg.ml⁻¹ Co⁺² was prepared by dissolving 0.4039 gm of CoCl₂.6H₂O in 1L H₂O. Hydrogen peroxide solution was prepared by dilution 11.6 ml of 35% H₂O₂ (sp.g 1.13 gm.ml⁻¹) up to 1L with distilled water. KMnO₄ (0.1M), sodium oxalate (0.1M) were prepared separately by dissolving (18.8g) and (13.39g) each in 1L distilled water respectively.

Procedure for determination:

As preliminary conditions, the following parameters were chosen, luminol concentration (3 × 10⁻⁵ M), H₂O₂ (0.01M), Co⁺² (0.6 ppm), H₂S O₄ concentration that used for preparation Co⁺² (5 × 10⁻⁵ M), flow rate for reagent 3 ml and Sample volume (200 μl).

Results and Discussion

In the absence of (D.S), the (CL) of luminol- H₂O₂ -Co⁺² system is intense. In this study, trace amounts of (D.S) were found to decrease the (CL) of luminol - H₂O₂ -Co⁺² system.

a. Effect of Luminol Concentration:-

The effect of luminol concentration on the CL intensity (ΔI) was studied (Fig.2), ΔI increased with increasing the luminol concentration up to 5 × 10⁻³ mol. l⁻¹.

After that the (CL) intensity started to decrease, this can be attributed to the complex formation between Co^{+2} and the excess luminol and the latter can act as a bidentate ligand⁽¹²⁾ which in turn consumes cobalt ions, thus the intensity of (CL) decreased.

b. Effect of H_2O_2 Concentration:-

The effect of H_2O_2 concentration on the net (CL) intensity was studied (Fig. 3). The ΔI increased with increasing the concentration of H_2O_2 up to 10^{-2} mol. l^{-1} . Above this concentration, the ΔI decreased with increasing of the H_2O_2 concentration, so the concentration of 10^{-2} mol. l^{-1} was selected to be the optimum and this is expected according to the literature⁽¹²⁾.

c. Effect of the acidity of Co^{+2} Solution:-

Figure 4 shows that the concentration of 5×10^{-3} mol. l^{-1} of H_2SO_4 , used to prepare cobalt ion gave the highest intensity and was chosen for further uses.

d. Effect of Flow Rate:-

Flow rate is an essential parameter in FIA. The results obtained (Fig. 5) show a continuous increase of CL intensity as the flow rate increases because the catalyzed oxidation reaction is so fast and reaches equilibrium state before departing the flow cell⁽¹²⁾. A total flow rate of 3ml /min was chosen as the suitable flow rate since it gives a reasonable CL intensity with the lowest reagent consumption.

E. Effect of Injected Sample Volume:-

A 50, 100, 150, 200 μl sample loops were tested. Fig. 6 represents the results obtained and indicate that a sample loop of 200 μl volume gave the best results.

Recommended Analytical conditions:-

According to the results obtained, the optimum conditions for

the determination of (D.S) using (FI-CL) method are given in table (1):-

Interferences Study:-

The effect of various foreign species on the determination of (D.S) was investigated. The presence of 100 ppm starch, glucose, lactose and sucrose gave no significant interfering effect on CL of (1-9) ppm (D.S) as shown on table2.

Calibration graph:-

A calibration graph (fig.7) of relative CL intensity Vs the (D.S) concentration was constructed at the optimal conditions. The regression equation is $y=19.017x + 7.0278$, $r=0.9969$.

The linear range for the determination of (D.S) is (1-9)ppm. The reproducibility of the method is satisfactory with a relative standard deviation of 0.23 % at $8 \mu\text{g ml}^{-1}$ (D.S).

Pharmaceutical Applications:-

The proposed method was applied to the determination of (D.S) in pharmaceutical preparation. The measured D.S. contents as a pure D.S and in diclofenac sodium tablets are listed in table (2). This table also includes the values obtained for the mentioned product using the reference procedure described in British pharmacopoeia⁽¹⁾.

The values presented on table (2) reveal good agreement between the proposed and the reference methods.

Conclusion

A flow injection CL method for the determination of D.S has been developed and compared with the method of British pharmacopoeia. The proposed method offers advantages of simplicity, rapidity, high sensitivity, low reagent consumption, and provides a linear range (1-9) ppm for the determination of (D.S). The reproducibility of the method is satisfactory with a relative standard deviation 0.23% and the detection limit is 0.42.

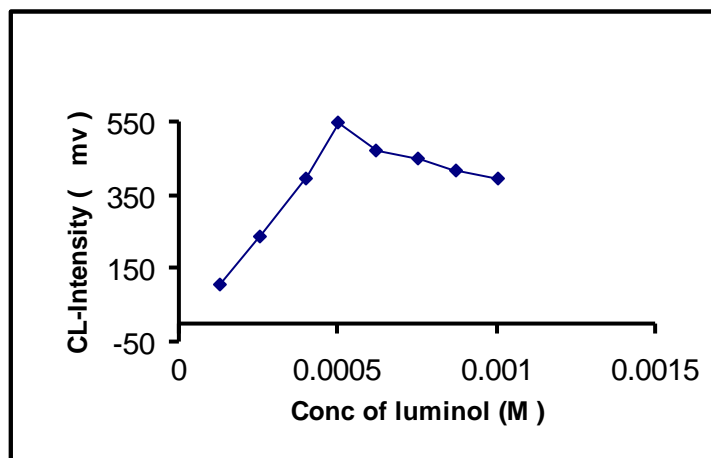

Fig. (2)Effect of luminol concentration on the intensity of chemiluminescence.

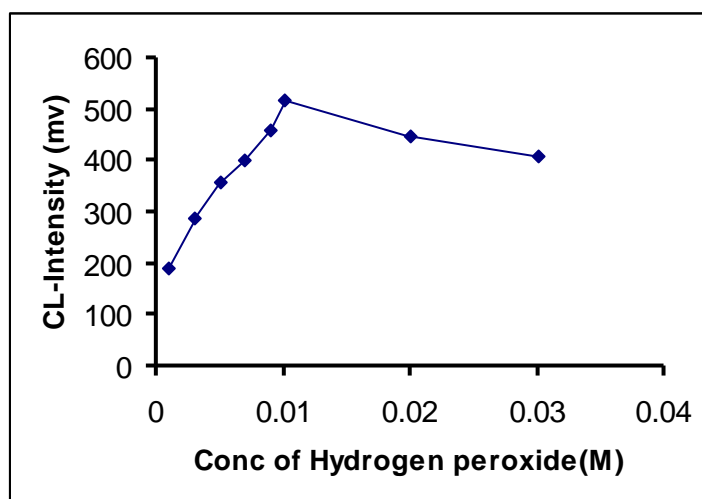

Fig. (3) Effect of H₂O₂ concentration on the intensity of chemiluminescence.

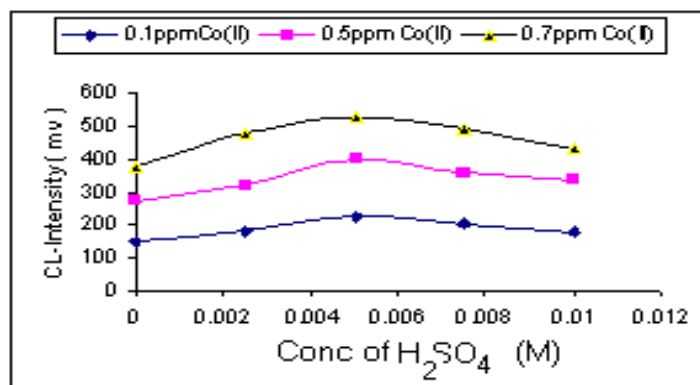

Fig. (4) Effect of the acidity of Co⁺² solution.

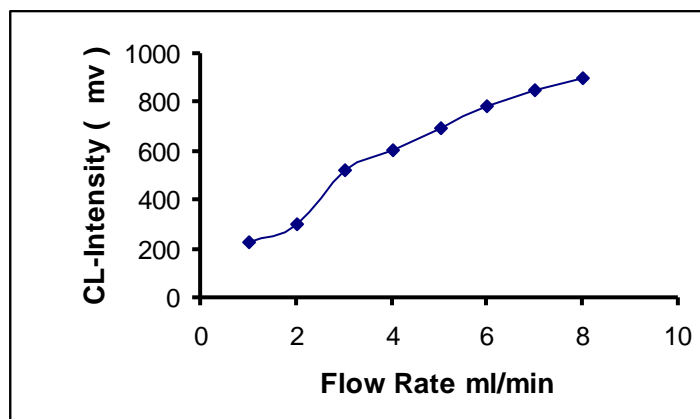

Fig. (5) Effect of flow rate on the intensity of chemiluminescence

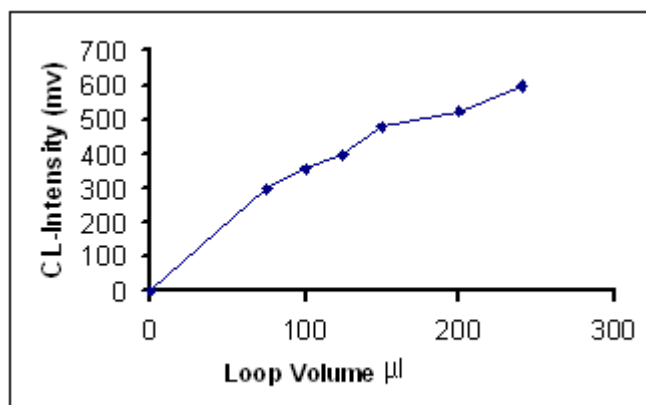

Fig.(6) Effect of injected sample volume on chemiluminescence intensity.

Table (1): Optimum conditions for the determination of(D.S) by (FI-CL).

Parameters	Value
Concentration of luminol	5×10^{-3} mole. l^{-1}
Concentration of H_2O_2	10^{-2} mol. l^{-1}
Concentration of Co^{+2}	0.7 ppm
Concentration of H_2SO_4	5×10^{-3} mole. l^{-1}
Injected volume(Drug)	200 μl
Flow rate	3 ml. min^{-1}

Table.(2) Effect of Interference on chemiluminescence intensity.

Interference	Interference Concentration $\mu g/ml$	CL intensity (m.v) Co^{+2}	Er%
Lactose	100	510	0.1
starch	100	515	0.2
M.H.B	20	512	0.2
P.H.B	20	513	0.6
Gelatin	100	510	0.5
Sodium saccharin	20	515	0.5
Aresoil	20	519	0.2
Mg-stearate	20	513	0.4
sucrose	100	514	0.1

Second method:

Determination of Diclofenac sodium using a new Rp-HPLC Method:

The determination of (D.S) by Rp-HPLC is based on the isocratic elution of the species on C18 column.

Optimization of Experimental conditions:-

Reagents

All chemicals and solvents were of analytical grade reagents. Acetate buffer was prepared by dissolving (1.64) gm of $\text{CH}_3\text{CO}_2\text{Na}$ in 1L distilled water. The pH of solution was adjusted to pH 5.5 with 0.1M CH_3COOH . After preparation, it was filtered and degassed in an ultrasonic bath prior to use. Stock solution (100 $\mu\text{g}/\text{ml}$) of (D.S) was prepared by dissolving 0.010gm (D.S) in 100ml of the mobile phase (16% acetonitrile with buffer acetate).

a. Effect of Different percentages of organic modifier in the mobile phase:

Acetonitrile was used as a typical phase modifier for this study and was mixed with (0.02 M) sodium acetate buffer (pH 5.5). The obtained results indicated that the retention times of (D.S) decreased as the percentage of acetonitrile increased from (12-20 %). The best sensitivity, and reasonable analysis time were obtained at 16% of a cetonitrile Fig.(8).

b. Effect of pH using 0.02M Acetate Buffer :-

In general, the t_R value of each species can be correlated with the values of pK_a of the solute molecule^(12,13). To study the effect of the pH of the mobile phase on the

elution of the studied compound, the pH of the mobile phase was varied from 5.4 to 7.4 with 0.4 intervals. Figure 9 shows that there is a little change in the in values of t_R with change of pH and was found that pH 5.5 gives the best peak symmetry.

c. Effect of flow rate of the mobile phase:-

The aim of choosing optimum flow rate is to perform the analysis in short time with a reasonable sensitivity and peak symmetry preventing any band diffusion⁽¹⁰⁾ which finally leads to high column efficiency. A change in the flow rate of the mobile phase from 0.8 to 1.8 ml min^{-1} caused a decrease in the analysis time from 1.81 to 0.82 minute. Figure (10) shows the effect of flow rate on the retention time showing that a flow rate of 1.0 ml min^{-1} is suitable.

d. Effect of temperature:

The effect of column temperature in the range of 25-45 $^\circ\text{C}$ on the t_R values of D.S was investigated. Generally, increasing column temperature in R_P - chromatography decreases t_R and column efficiency increases by decreasing mobile phase viscosity^(14,15), which in turn lowers the pressure of column head. Figure 11 shows the relation between $\log K'$ and $1/T$. A 30 $^\circ\text{C}$ was found to give symmetrical band shape.

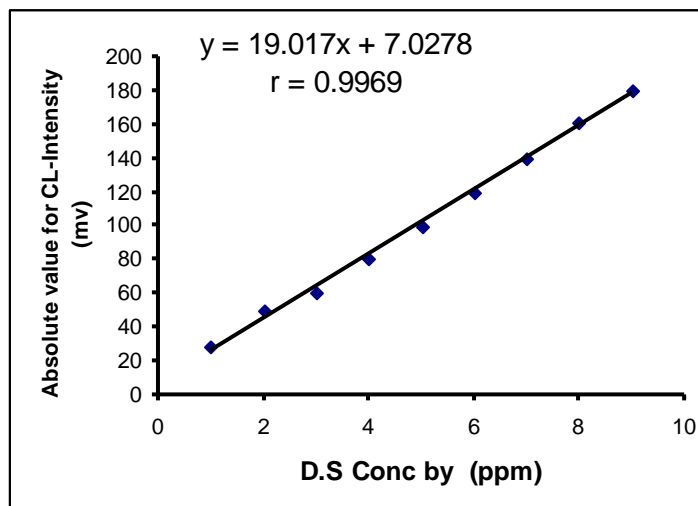

Fig. (7) calibration graph for the determination of (D.S) by FI-CL.

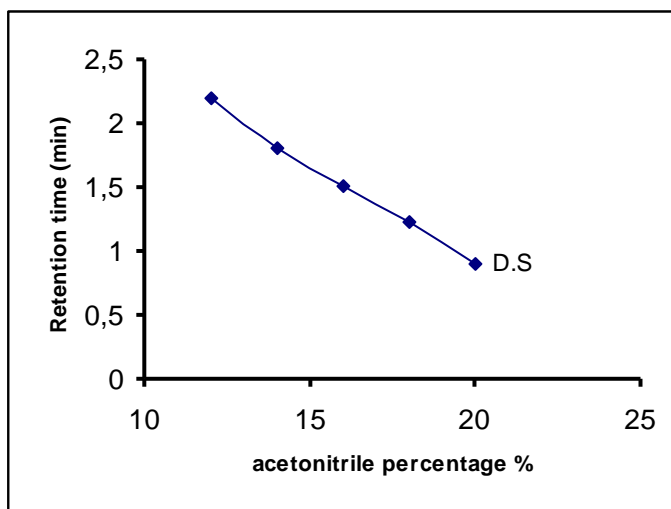

Fig.(8)Effect of organic modifier percentage (CH₃CN%) on the retention of (D.S).

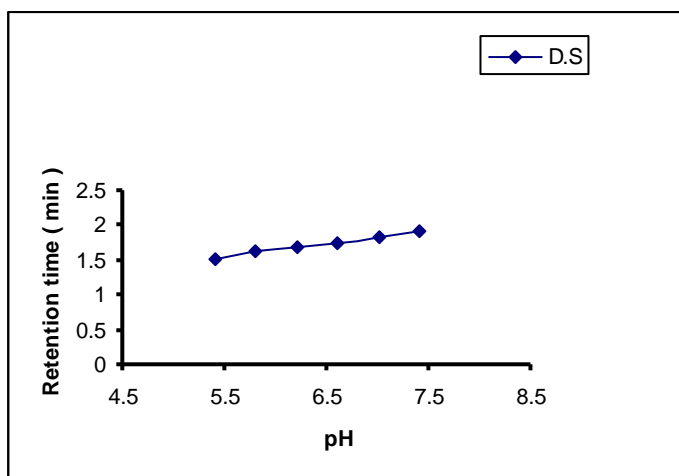

Fig. (9)Retention time of (D.S) on Rp-C18 versus pH.

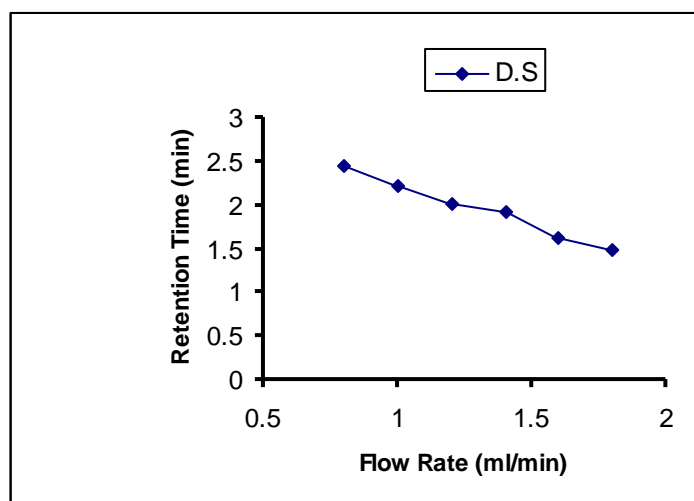

Fig. (10) Plot of t_R of drug against flow rate of the mobile phase.

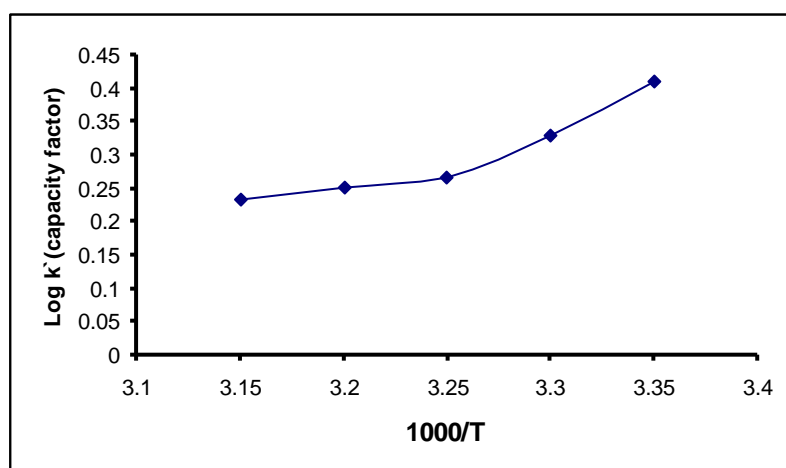

Fig.(11) Plot of $\log k'$ of drug against $1/T$.

Recommended Analytical Conditions:-

According to the results obtained, the optimum experimental conditions established by reversed phase Rp-HPLC method are given and summarized in table3.

Calibration Graph:-

The recommended analytical conditions table(4) were used to construct calibration graph of

Diclofenac sodium by plotting the concentration (mg. ml^{-1}) of drug against the peak area.

A linear calibration graph for the determination of Diclofenac sodium was obtained in the range of $(0.01-0.06) \text{ mg.ml}^{-1}$ fig.(12). The analysis data obtained from calibration graph are summarized in table (5). The linear regression equation of Diclofenac sodium is $y= 0.0002x-10^{-7}$.

Table (3) Application of the (D.S) determination in pharmaceutical preparation

Sample	*Recovery%		RSD%
	Proposed method	Standard method	
Pure Diclofenac sodium	98.87	99.25	0.236
Diclofenac sodium tablets	99.50	99.32	0.221

*Each result is the average of three determinations.

Table (4): The recommended analysis conditions for the determination of Diclofenac sodium using Rp-HPLC method.

Parameter	Recommended value
Organic modifier	16% Acetonitrile
Injected sample volume	20 µl
Buffer	(0.02M CH ₃ COO Na)
pH	5.5
Flow rate	1.0 ml.min ⁻¹
Column temperature	30 C ⁰
Detector	UV. Detector 220 nm

Table (5) Analytical data for the determination of Diclofenac sodium using RP-HPLC.

Analytical data	Value
Detection limit (D.L)	3.4 µg .ml ⁻¹
Correlation coefficient(r)	0.9945
Linear range	(0.01-0.06) mg. ml ⁻¹
Average Recovery%	95.9
RSD%	0.72

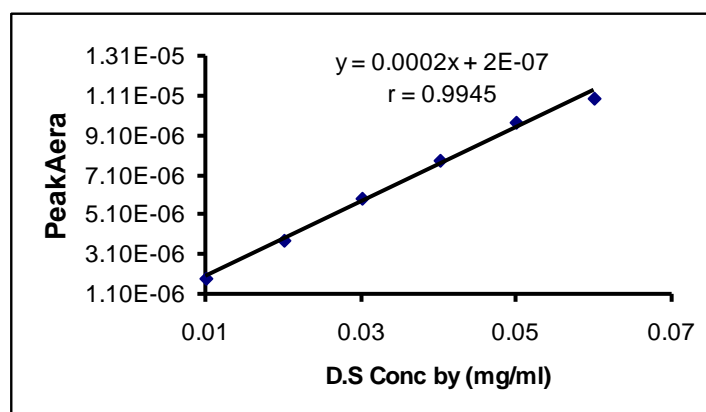

Fig. (12) Calibration graph for the determination of Diclofenac sodium.

Application:-

The proposed method was applied to the determination of (D.S) in pharmaceutical preparation. The measured (D.S) contents are listed in table (5), this table also includes the values obtained for the analysis of the same samples by using the reference procedure described in British pharmacopoeia⁽¹⁾. The values represented on table(6) reveal a good agreement between the proposed and the reference method with reasonable sensitivity and linear range (10-60) ppm. The reproducibility of the method is satisfactory, with a relative standard deviation 0.72.

Comparison between the two methods:-

Table(7) summarized the statistical values for FI-CL and Rp-HPLC methods. The calculated F-test is less than F-table(4.39) at 95% confidence indicating that no significant difference among Rp-HPLC ,FI-CL and B.C. methods .However the comparison

between Rp-HPLC and FI-CL methods shows that the latter method is more precise table(8).

Conclusions.

First Method FI-CL.

A flow injection CL method for the determination of D.S has been developed utilizing the decrease of the CL intensity by (D.S). In comparison with British pharmacopoeia method the proposed method offers advantages of simplicity, rapidity, high sensitivity and low reagents consumption and provides a liner range of (1-9)µg. ml⁻¹.

Second Method Rp-HPLC.

This method includes a simple and sensitive high-pressure liquid chromatographic method for the determination of Diclofenac sodium in pharmaceutical preparation. Moreover,Rp-HPLC method gives good precision (RSD%0.72%) and accuracy(Recovery % 96%) .In addition, the analysis time is much short for this method with a liner range of(10-60) µg ml⁻¹.

Table (6): Application of RP-HPLC method for the determination of (D.S) in pharmaceutical preparation.

Sample	Recovery%		RSD%
	Proposed	Standard	
Pure Diclofenac sodium	96.0	99.0	0.72
Diclofenac sodium tablets	96.6	99.5	0.66

Table (7): The statistical comparison results for the two methods.

The method	Regression equation	D.L	Linearity µg ml ⁻¹	r	Recovery	RSD %
FI-Cl	y=19.01x +7.02	0.42	1-9	0.9969	98.48	0.23
Rp-HPLC	y = 0.0002x -2×10 ⁻⁶	3.40	10-60	0.9945	96.6	0.72

Table(8):F-test⁽¹⁶⁻¹⁷⁾ between Rp-HPLC ,FI-CL and B.C. methods

F-test between B.C. and Rp-HPLC	F-test between B.C. and FI-CL	F-test between Rp-HPLC and FI-CL	F-table At 95% confidence
0.375	3.05	9.15	4.39

References

1. *British pharmacopoeia* on CD-ROM, 2002, 2.
2. The *Merk Index* on CD-ROM. 12th Edition, Copyright by Merk CO. Inc., Whiteho , 2000 .
3. *British National Formulary* (BNF) No. 35, 1998 published by the British Medical Association Royal Pharmaceutical Society of Great Britain.
4. Hassan, S., S., M., Abdel Aziz,R.M, Abdel samad ,M.S.*Analyst*, (London)1994, **119(9)** (1993-1996).
5. Prado,M.S.A ,Steppe ,M andTavares,M.F.M,*J.Capillary Electrophoresis* Brazil ,1999,6(125-129).
6. Damian, P.C., Bearzotti, M.; cabezon, M.A.; olivieri , A.C., *Journal of Pharmaceutical and Biomedical Analysis*, Argentina,1999, **20(3)**, 587.
7. Liu, S.C, Tsai, T. H , *Journal of Chromatography* Taiwan,2002, **769(2)**, 351.
8. Roskar,R. ; Kmetec, V., *Journal of Chromatography*,Liabljana Slovenia, 2003, **788(1)**, 57.
9. Krzek. k, J., ; starek, M., *Journal of Chromatography and Biomedical analysis*, Polana,2002, **28(2)**, 227.
10. Mayer,B.X.;Namiranian,K,Dehganyar, P. ; *Journal of Chromatography and Biomedical analysis*, Austria, 2003, **33(4)**, 745.
11. Garcia, S., Sanchez-Pedreno, *Mikro.chimica.Acta*, Spain, 2001, **136(1-2)**, 67.
12. S.Albala-Hurtado,M.T Veciana-Nognes,Vidal.Carou and Marine-Font.; *J.Food. Sci.*, 2000, **65(6)**,1052,.
- 13..Horvanth, Melanderw C.S and I. Mdnar ; *Anal. Chem.*,1977, **49**, 142.
14. Zakana & P.R. Broun; *J. Chromato.*,255,151,1983.
15. N. Tanaku, H. Goodell and B.L. Karger; *J. Chromato*, 1978, **158**, 233,.
16. Saline , L.A., ; *Chemilinescent inhibition and activation for determination of nitrogen drugs and acid* , 1992 , M.Sc. Thesis , University of Salah Al-deen p.40-41.
17. J. Roso, *Advanced in Physicochemical Experiments*, Ellis Ho/Wood Series, London, 1964, P67.
- 18.Miller.J.C. & Miller, J.N., *Statistics for analytical chemistry*,1989, p.60.